

Trial organized in Blackcurrant farm in France on 17th june

Information about the robot:

- Autonomie Robot replacing tractor (RTK guidance)
- Possibility to link any equipment (such as mechanical weeder)
- Diesel engine (6-8l/ha)
- Hydraulic pump
- Autonomy : 15 to 20 hour
- Maximum speed : 13km/h
- Possibility to purchase or to rent the robot depending on the provider
- Price idea : 200k€ to 210 k€

Could be an opportunity for blackcurrant weed management



AgBot
2.055W3

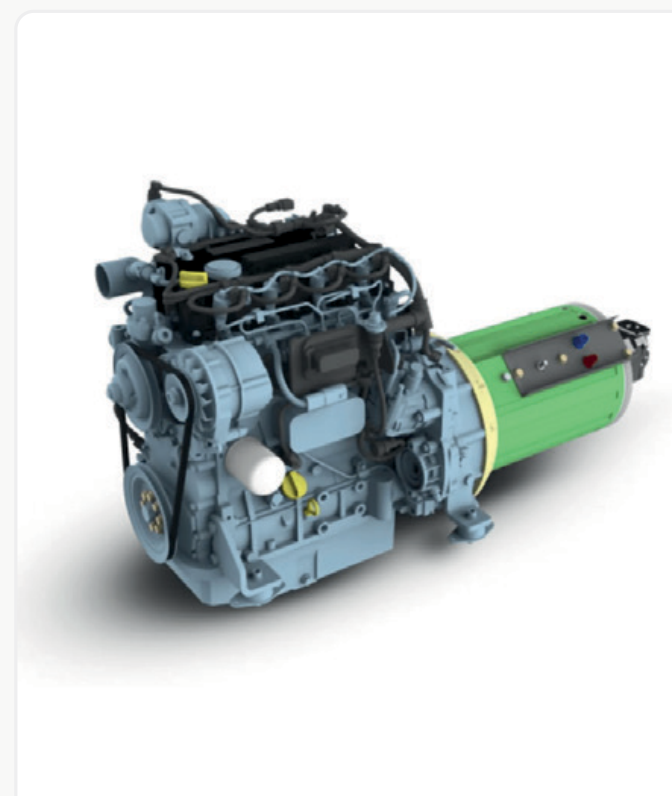

Antriebsstrang

Deutz Dieselmotor
2,9l 4-Zylinder Deutz Dieselmotor, Stufe 5 mit 55kW / 75PS, max. Drehmoment von 300Nm

Elektrischer Antriebsstrang
Elektrischer Antriebsstrang mit einem Geschwindigkeitsbereich von 0-13,5 km/h

Elektrische Zapfwelle
Optionale elektrisch angetriebene Zapfwelle (bis zu 50kW) +/- 1.200 1/min, variabel einstellbar

HighVoltage connectors
Optionale Hochvolt Anschlüsse (bis zu 50kW und 700V)

Diesel Tank
170l Diesel Tank



Hydraulik

Hydraulikpumpe
Hydraulikpumpe mit 85 l/min bei 210 bar

Steuerventile
Bis zu 3 doppeltwirkende proportionale Steuerventile

Heckhubwerk
Dreipunkt-Heckhubwerk Kat. 2
2,5t maximale Hubkraft an den Haken

Load Sensing
Optionales Load Sensing

Sicherheitssysteme

- ✓ Geofence-System
- ✓ Optische Kommunikationsleuchten
- ✓ Akustisches Warnsignal
- ✓ Not-Aus-Schalter rund um die Maschine

System zur Hinderniserkennung

- ✓ LIDAR-Sensor auf der Maschine
- ✓ Ultraschallsensoren in den Sicherheitsbumper integriert
- ✓ Radarsensoren in den Sicherheitsbumper integriert
- ✓ Berührungsempfindliche Sensoren in den Sicherheitsbumper integriert

Abmessungen & Gewicht

Länge: 3.850mm
Höhe: 1.500mm
Radstand: 2.400mm
Breite: min. 1.350mm
Leergewicht: 2,8t

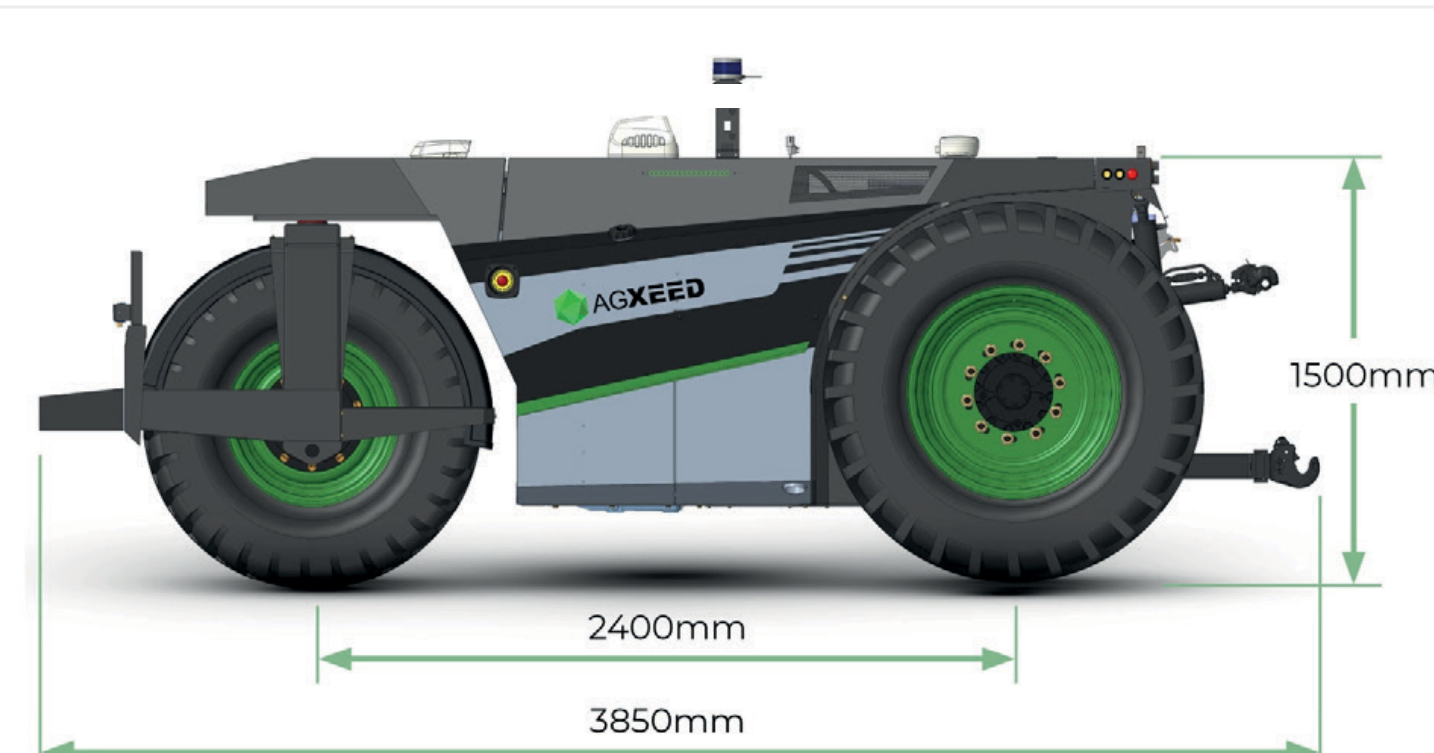

Die Spezifikationen und Abmessungen unterliegen einem kontinuierlichen Entwicklungsprozess. Angaben können sich im Laufe der Zeit ändern.

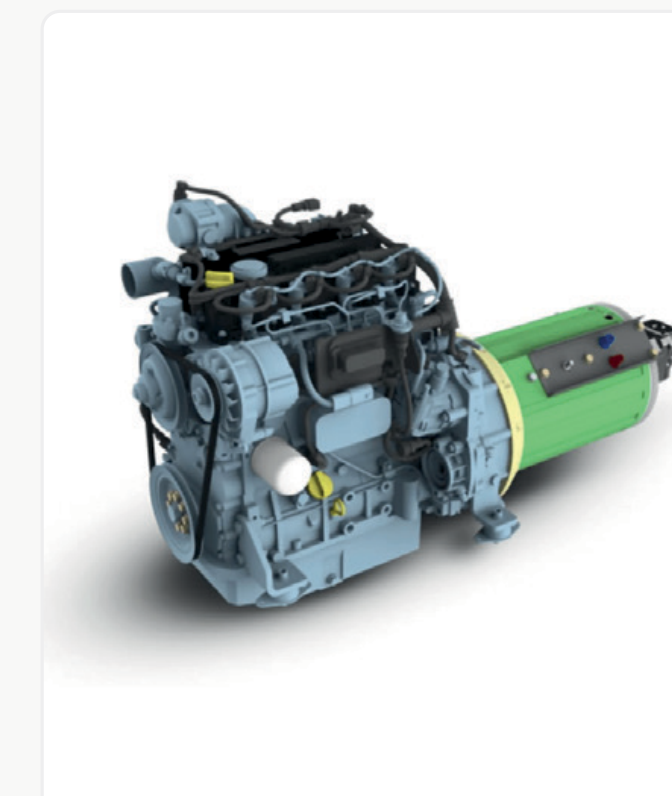

Drive train

Deutz Diesel Engine
2,9l 4-stroke Deutz Diesel Engine, stage 5 with 55kW / 75hp, max. torque of 300Nm

Electric drive train
Electric drive train with a speed range from 0-13.5 km/h

Electric driven PTO
Optional electric driven PTO (up to 50kW) +/- 1200rpm completely variable in adjustment

HighVoltage connectors
Optional HighVoltage connectors (up to 50kW und 700V)

Diesel tank
170l diesel tank

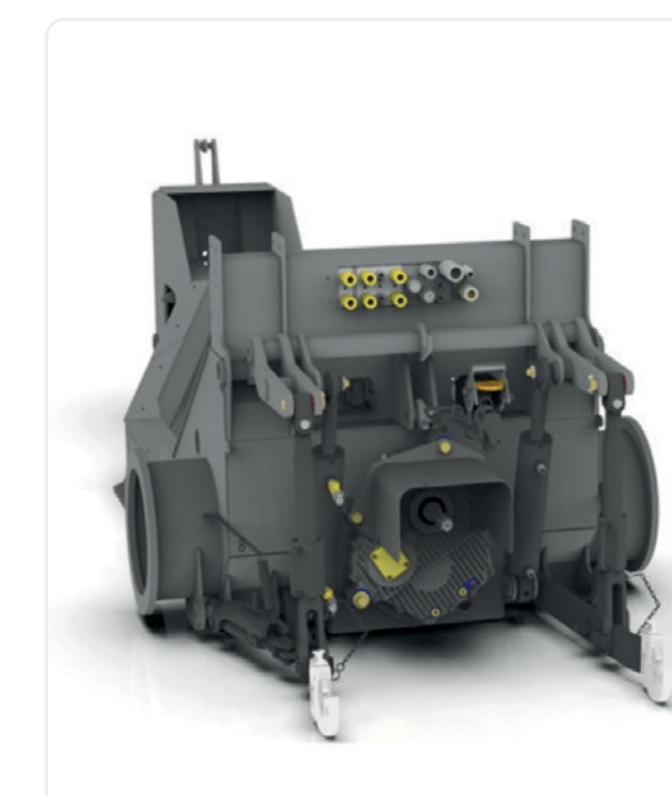

Hydraulics

Hydraulic pump
85l/min at 210bar hydraulic pump

Spool valves
Up to 3 double-acting proportional spool valves

Rear linkage
Three-point rear linkage cat 2
2,5t maximum lift capacity at hooks

Load sensing
Optional Load Sensing

Safety measures

- ✓ Geofence system
- ✓ Visual indicator lights
- ✓ Audible warning alarm
- ✓ Emergency stop buttons around the machine

Obstacle detection system

- ✓ LIDAR sensor on the top of the machine
- ✓ Ultrasonic sensors integrated into the safety bumper
- ✓ Radar sensors integrated into the safety bumper
- ✓ Contact sensitive bumper integrated into the safety bumper

Machine dimensions

Length: 3850mm
Height: 1500mm
Wheelbase: 2400mm
Width: min. 1350mm
Empty weight: 2.8t

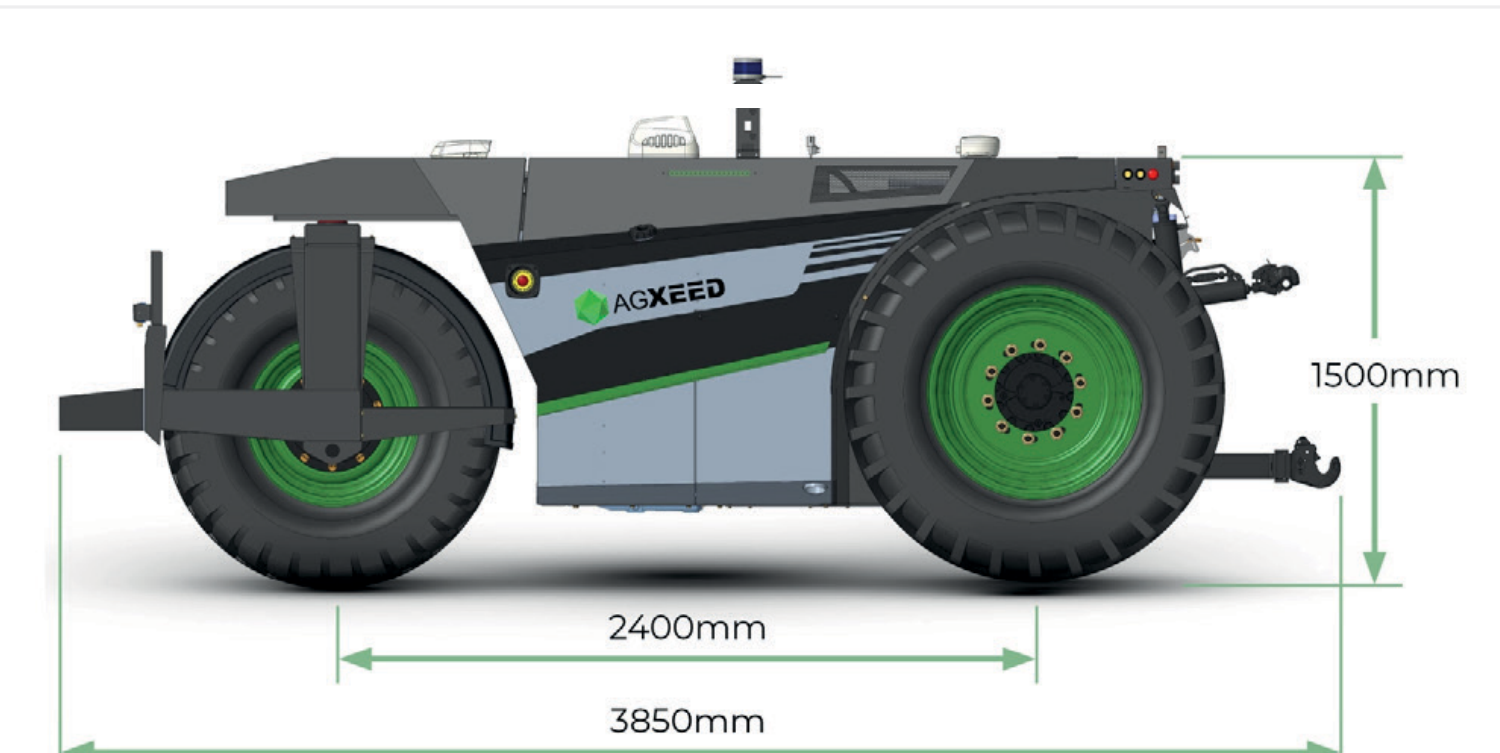

All specifications and dimensions undergo continuous development processes. Values and configurations may change over time.